

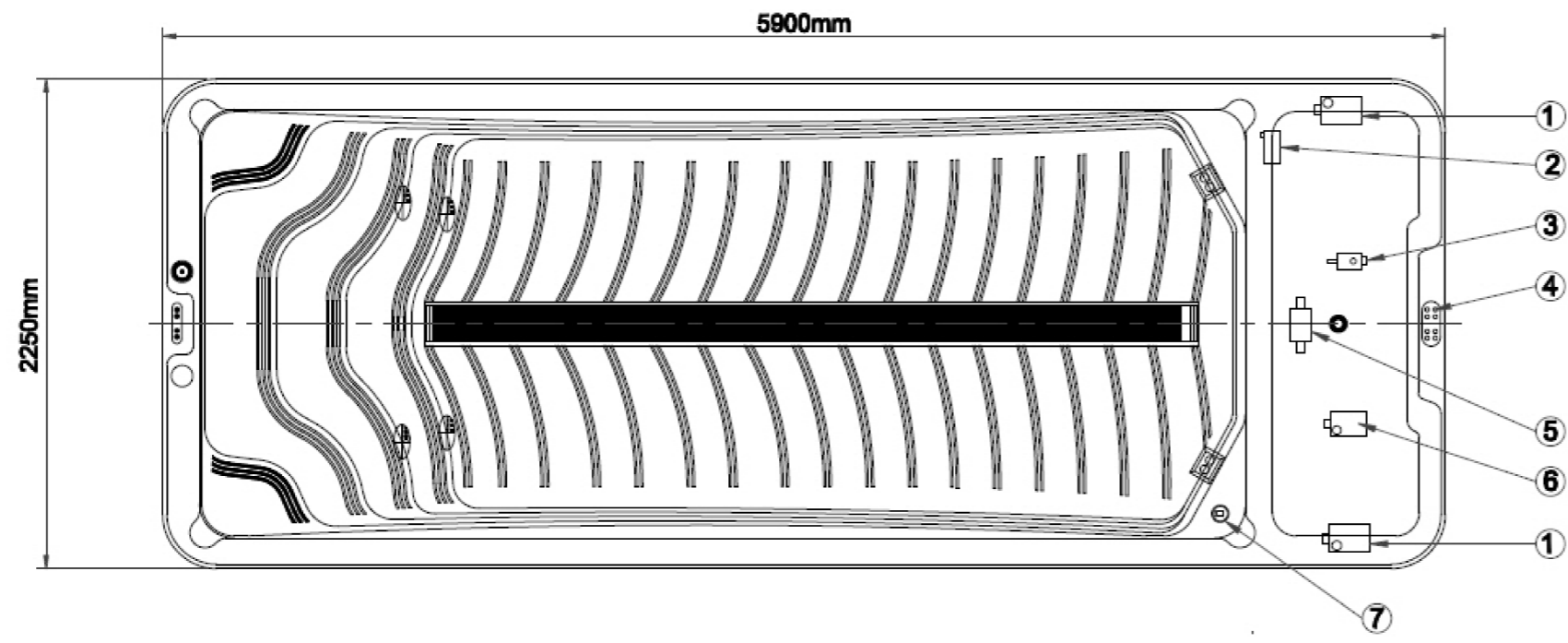

Nº	Descripción	Quant.	unit
1	3.5 HP Inverter Water Pump	2	pcs
2	CP Ozone Generation	1	pc
3	1HP Circulation Pump	1	pc
4	Top Panel	1	pc
5	Control Box (3KW Heater)	1	pc
6	3HP Single Speed Pump	1	pc
7	Inverter control panel	1	pcs

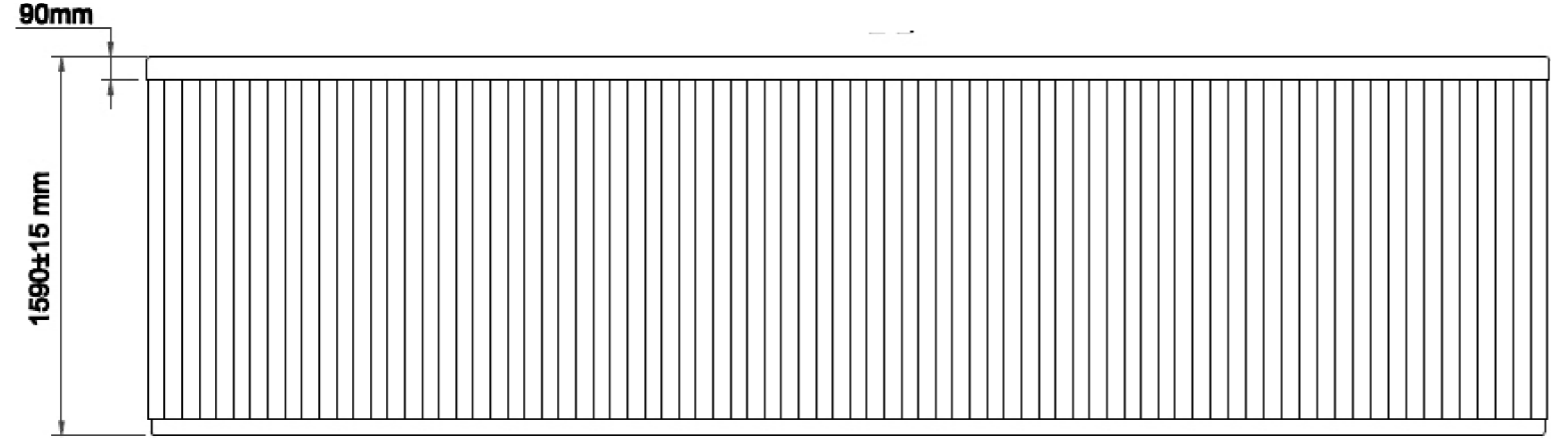
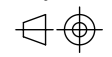

According to our policy of continuous improvement, dimensions, features or components of this product can be partially or completely changed without prior notice. It's Customer responsibility to verify that this is the last version of the drawing

00				11/05/2015	E. Graells	Drawing creation	COMMERCIAL			
Change No.	Date	Name	Modification							
Remarks										
Dimensions in mm. General Tolerances +/- 10mm										
Drawn	11/05/2015	E. Graells					Part Number	Rev.	First Angle Projection	
Checked	11/05/2015	V. Saiz					61444	00		
Scale	General Tolerance DIN 7168 ISO 2768g									
Sheet	1/1									
Property of IBERSPA S.L. Avda. Pla d'Urgell 2-8 25200 Cervera, Spain. Don't use without permission. Keep this information confidential and use it solely for the permitted purpose.										